

## **CHEM-GARD<sup>®</sup> CG** *Thermoplastic* **CENTRIFUGAL PUMPS**

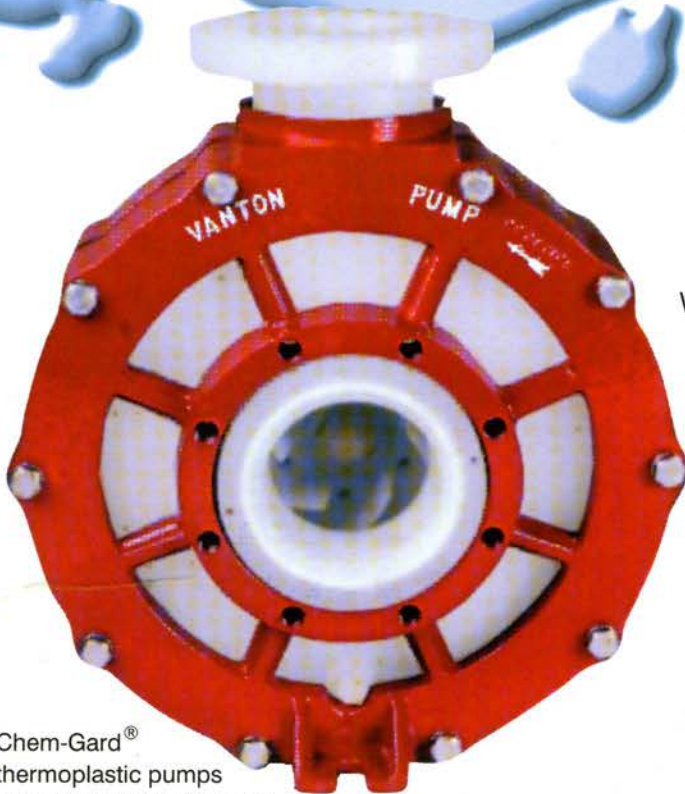

Chem-Gard<sup>®</sup> thermoplastic pumps are also available to meet ANSI and DIN specifications

■ PVC ■ POLYPROPYLENE ■ PVDF ■ ECTFE  
5 to 1450 GPM – Heads to 400 FEET  
Temperatures to 275°F

Vanton Chem-Gard<sup>®</sup> thermoplastic heavy duty pumps are designed and constructed to maximize the unique properties of solid homogenous chemically inert thermoplastics. They are not plastic lined metal pumps nor metal pump designs made with plastic components.

They have been engineered to efficiently and reliably transfer corrosive, abrasive and other aggressive fluids, as well as deionized and ultrapure water, pharmaceuticals, reagent grade chemicals and similar liquids which must remain free from metallic contamination. To assure no metal-to-fluid contact, shafting is sleeved in thermoplastics and mechanical seals are reverse mounted.



Rugged homogeneous thermoplastic pump components assure dependable performance

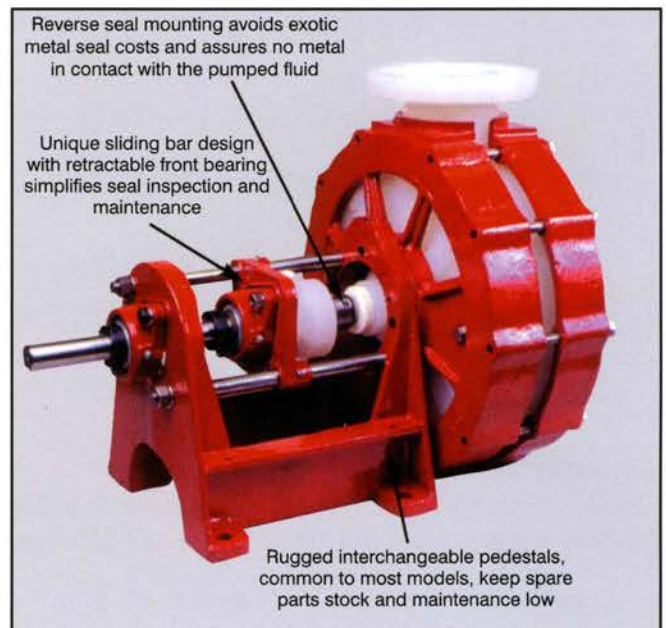

Reverse seal mounting avoids exotic metal seal costs and assures no metal in contact with the pumped fluid

Unique sliding bar design with retractable front bearing simplifies seal inspection and maintenance

Rugged interchangeable pedestals, common to most models, keep spare parts stock and maintenance low

# CHEM-GARD® THERMOPLASTIC CENTRIFUGAL PUMPS

MODELS: CG-200 to CG-2400

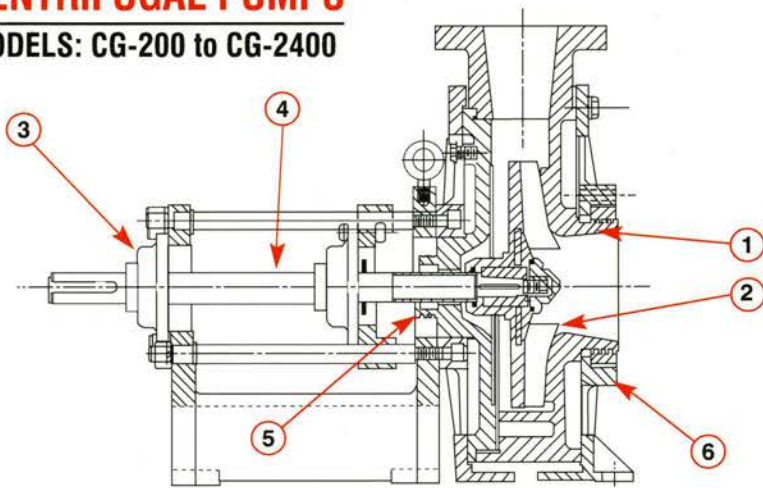

- 1. Pump Casing and Cover:** Molded from virgin, homogeneous thermoplastics.
- 2. Impeller:** Dynamically balanced, molded from virgin, homogeneous material, with an imbedded, stainless steel insert. Key driven to assure positive drive.
- 3. Drive Pedestal With Retractable Front Bearing:** Designed to provide a wide open seal area. This simplifies inspection, assures minimum shaft overhang and deflection, and reduces maintenance.
- 4. Shaft:** Stainless steel large diameter shaft with wetted end completely sleeved with thermoplastic to isolate it from the fluid.
- 5. Mechanical Seals:** The pumps are designed to permit the use of all standard single and double mechanical seals without pump modification. The seals are reverse mounted with the nonmetallic seal component inboard to avoid any metal-to-fluid contact and to make it unnecessary to utilize high alloy or exotic metal seal components
- 6. External Cast Iron Armor:** Completely painted with 2-part epoxy chemically resistant coatings for protection against atmospheric corrosion

## PERFORMANCE CHARACTERISTICS — 60 Hz

50 Hz curves available upon request

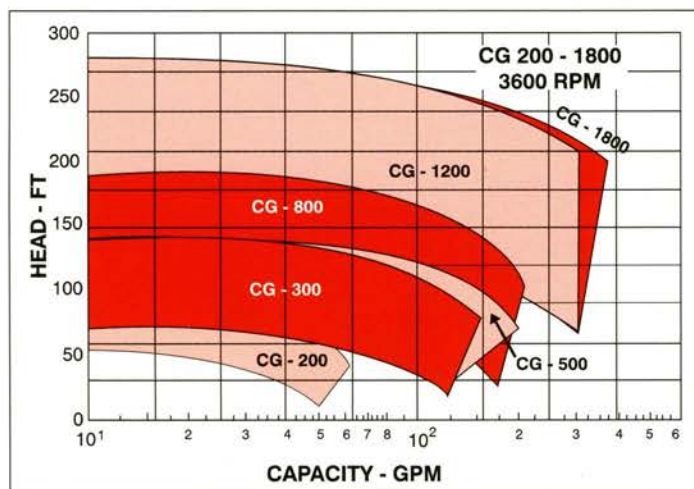
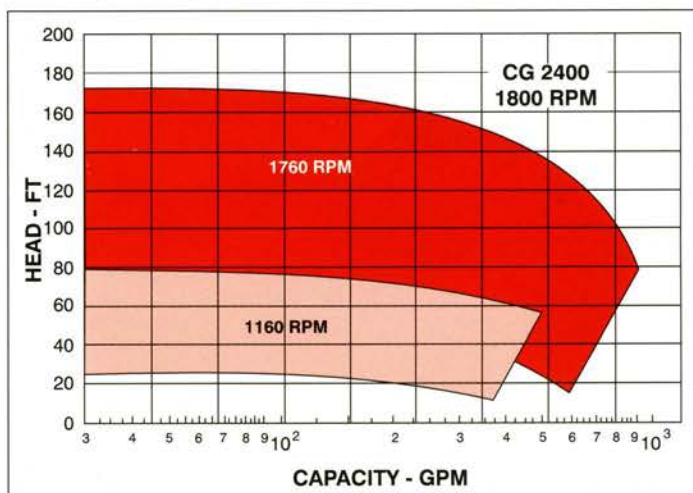
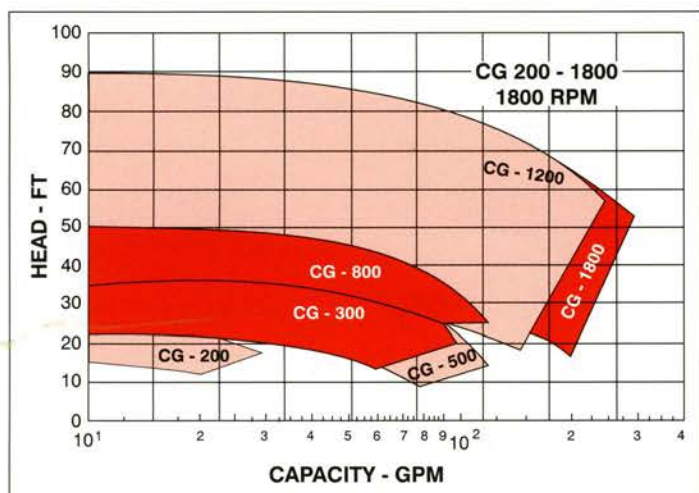

NOMINAL DIMENSIONS (Inches)				
MODELS	OVERALL LENGTH	HEIGHT	WIDTH	SUCTION/DISCHARGE
CG 200	21	10 3/4	9	1 x 1
CG 300	23 1/2	11 1/2	10	1 1/2 x 1 1/2
CG 500	23 1/2	11 1/2	10	2 x 1 1/2
CG 800	23 1/2	11 1/2	10	2 x 1 1/2
CG 1200	25	13 3/4	12 3/4	3 X 2
CD 1800	25	13 3/4	12 3/4	4 x 3
CG 2400	32	23	22	6 x 4

- Dimensions and specifications subject to change.
- Catalog sheets are available on all Vanton models including ANSI designs, self priming, vortex, magnetic drive and close coupled pumps.

www.vanton.com

# VANTON

**VANTON PUMP & EQUIPMENT CORP**

201 Sweetland Avenue • Hillside, NJ 07205-1793  
 Tel. 908-688-4216 • Fax: 908-686-9314  
 E-mail: mkt@vanton.com

Europe: Vanton Pumps, Ltd., Cheshire, England  
 E-mail: sales@vantonpump.com